

# Chillers - Variable Speed

## with Pressure Independent Temperature Control

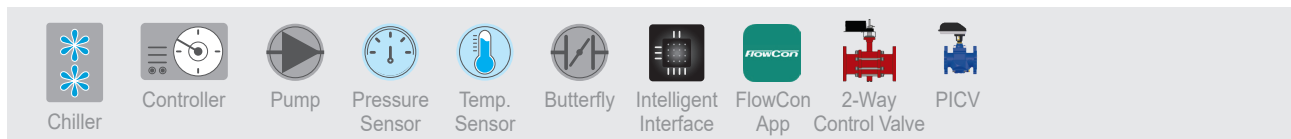
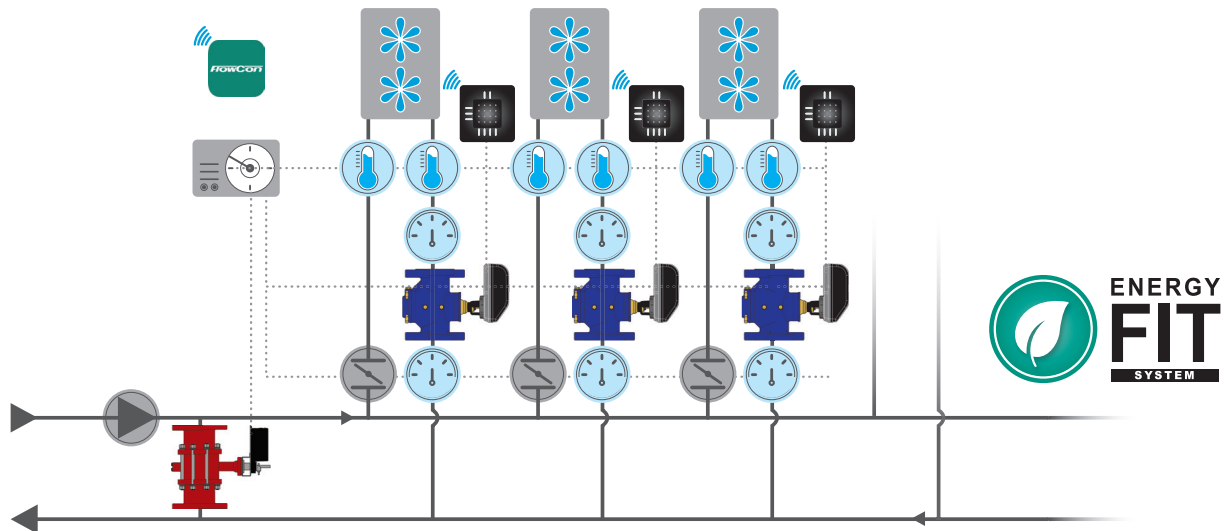

### System Functionality:

Chillers are either designed for in- or outdoor location, and the function of a chiller is to provide the correct amount of chilled water to a building's A/C system. Chillers are normally seen in large-size buildings and thereby handling larger flow rates. Without proper balance and control, energy consumption,  $\Delta T$  and hence operating costs will run wild. This can be prevented by installing a true pressure independent temperature control valve (PITCV) on every chiller. The PITCV will, by controlling on  $\Delta T$  alone, help significantly to reduce energy consumption and operating costs and increase the building's overall energy performance and anticipate in the task of energy certification.

### Requirements:

A PITCV will only react to  $\Delta T$  changes and consequently adjust the flow by altering actuator position. System pressure fluctuations are mechanically absorbed by the included PICV. By controlling chiller performance on  $\Delta T$ , flow requirements may be reduced, resulting in significant energy savings and optimized comfort at all times.

### Solutions:

The solution is to mount a PITCV on every unit and FlowCon offers:

- FlowCon Energy FIT System

### Benefits:

- All-in-1 solution incl. PICV, temperature and pressure sensors, flow and BTU metering.
- User friendly w/ easy direct setting on display actuator
- Complete overview of energy and flow with simple monitoring via Bluetooth® to FlowCon App or via BACnet to BMS
- No piping restrictions - the most compact system on the market
- Cost savings due to optimized energy consumption and improved efficiency
- True PITCVs with full pressure independent  $\Delta T$  control.

